

PLANNING AND DEVELOPMENT PROJECT PREVIEW MEETING

December 16, 2025

When:

4:00 - 6:00 PM

4th Tuesday Every Month

*November & December
will be the third Tuesday
due to holidays.*

Location:

Prisma Health Welcome Center at Unity Park

111 Welborn Street

Greenville, SC 29601



Location Information

Prisma Health
Welcome Center at
Unity Park

111 Welborn Street
Greenville, SC 29601



Overview

- The Project Preview Meeting is a monthly meeting hosted by the City of Greenville for the community to learn about various upcoming planning and development projects.
- The session is an open-house format. Projects are presented at individual stations in one room. There is no scheduled presentation. The public may attend any time between 4:00 and 6:00 PM.
- Project representatives will be available at each station. The public may ask questions, provide input and share concerns about any project or proposal.
- Certain projects may be presented from 6:00 - 7:00 PM during some months. These will be specifically advertised in advance. Otherwise, the standard hours are 4:00 - 6:00 PM.

What types of projects are presented?

- The Greenville Development Code requires certain projects to participate in a Project Preview Meeting before submitting an application. The following projects are required to participate:
 - Zoning map amendment (rezoning)
 - Subdivisions with new roads or 3+ lots
 - Street naming or re-naming
 - Major Certificate of Appropriateness requests - Urban Design Projects
 - Major Certificate of Appropriateness requests - Historic Projects
 - Residential projects containing 12 or more units
 - Requests for Special Exception permits abutting residentially zoned properties
- In addition, the City may present updates and information on various other planning initiatives, engineering projects, capital projects, and more.

Required Step in Development Process

- **The city has not received formal applications for projects presented at the Project Preview Meeting.** Some material may be conceptual in nature or require additional design work before it is submitted to the City.
- The meeting provides an opportunity for public comments and input to be given directly to the developer, who may modify their project in response to community feedback before submitting an official application.
- If a project has major changes after the meeting, it may be required to present at another Project Preview Meeting—so that the community can see the changes before the application is submitted.

PROJECTS AND APPLICATIONS FOR:

December 16, 2025

PROJECT PREVIEW MEETING

All projects presented between 4:00 - 6:00 PM



Multifamily Residential Development: Ridge Road

Note: The City has not received a formal application for this item. The PPM is required before submitting a formal application to receive community input and feedback. Presentation at a PPM does not constitute City endorsement or approval of a project.

Multifamily Residential Development: Ridge Road

- **Address:** Unaddressed
- **Parcel Number:** M012030100104
- **Existing Zoning:** IX
- **Request:** Development of a multifamily rental cottage/townhome community
- **Next Step:** Planning staff review

Contact:

Please contact Planning staff for applicant information

Email: planning@greenvillesc.gov

Phone: 864-467-4476

Multifamily Residential Development: Ridge Road

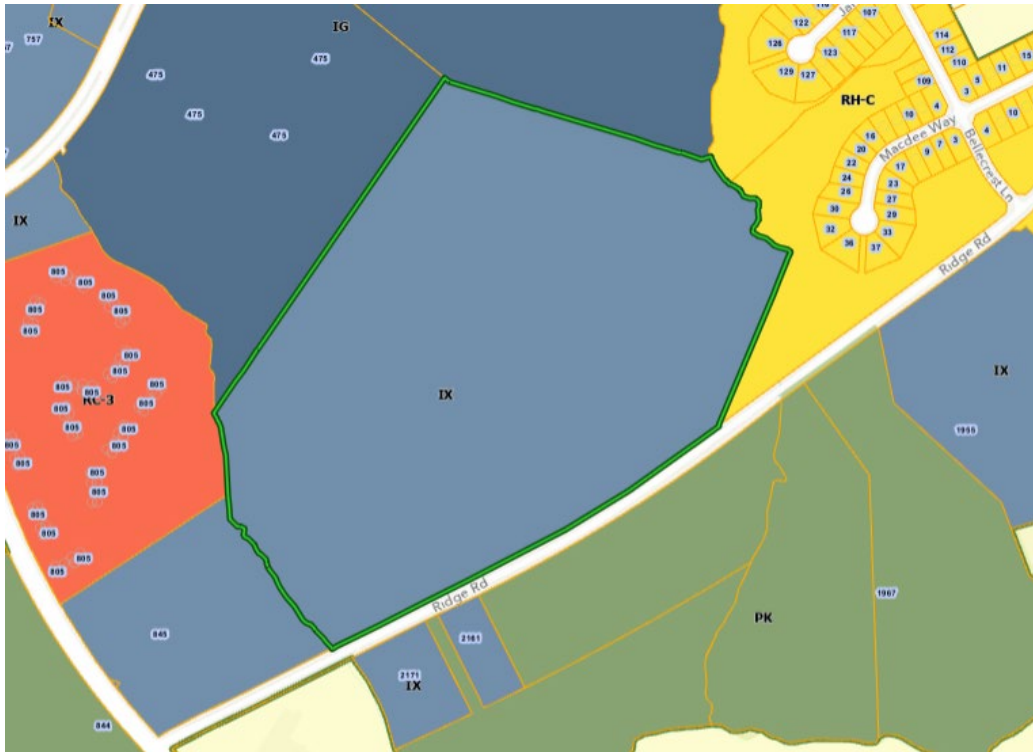

Multifamily Residential Development: Ridge Road



Multifamily Residential Development: Ridge Road

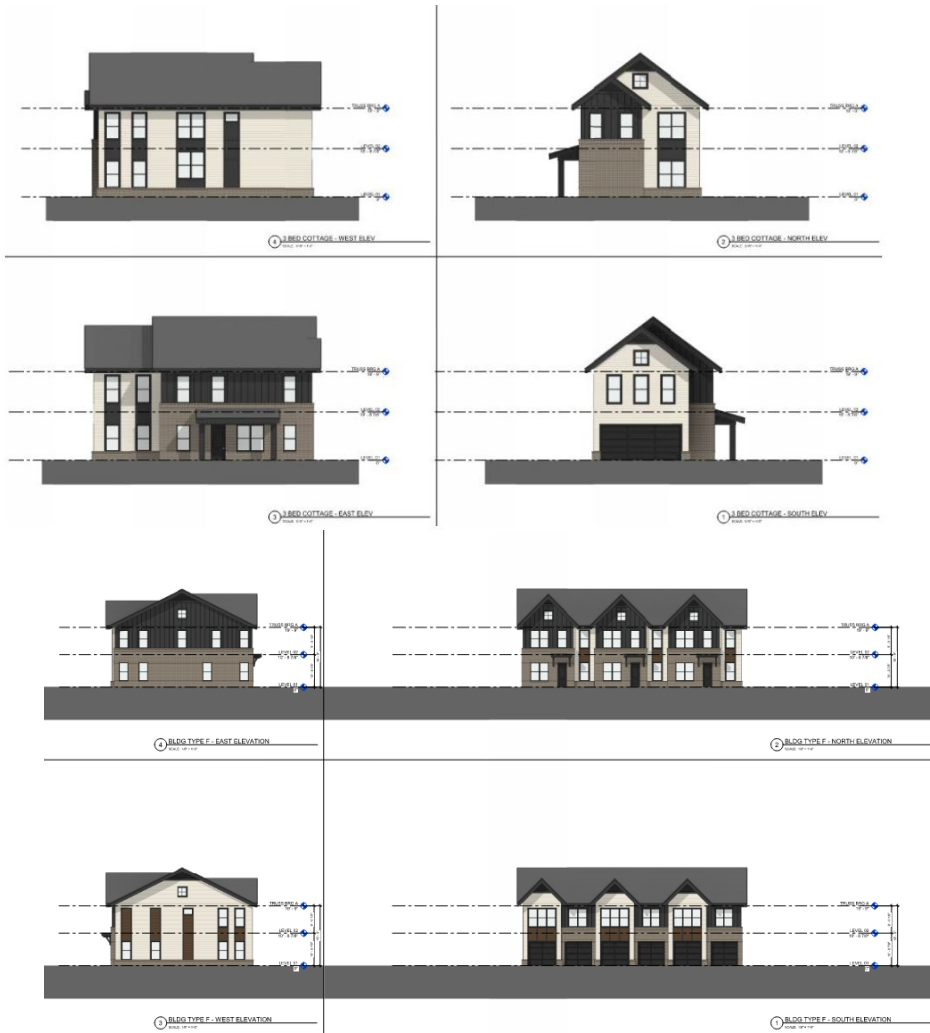

Single Family Residential Development: 606 Augusta Street

Note: The City has not received a formal application for this item. The PPM is required before submitting a formal application to receive community input and feedback. Presentation at a PPM does not constitute City endorsement or approval of a project.

Single Family Residential Development: 606 Augusta Street

- **Address:** 606 Augusta Street
- **Parcel Number:** 0095000100200
- **Existing Zoning:** MX-2
- **Request:** Development of 6 single family residential units
- **Next Step:** Planning staff review

Contact:

Please contact Planning staff for applicant information

Email: planning@greenvillesc.gov

Phone: 864-467-4476

Single Family Residential Development: 606 Augusta Street



Single Family Residential Development: 606 Augusta Street

COPPER BUILDERS
BUILT ON TRUST

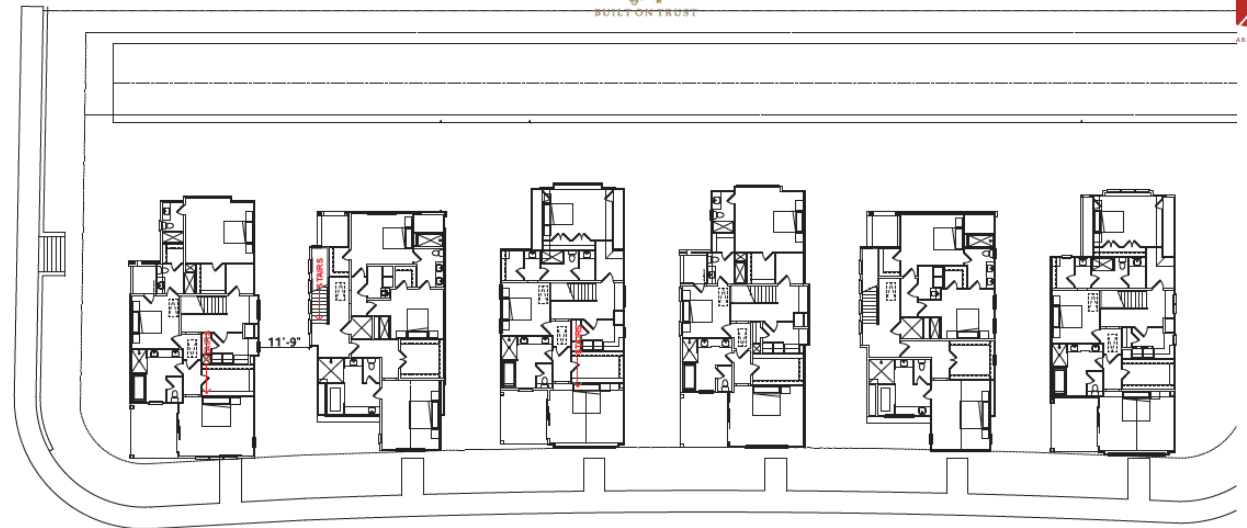

Beaty

Griffith

Lux

Augusta Cottages
Greenville, South Carolina
111725



Townes Street Road Diet

Note: The City has not received a formal application for this item. The PPM is required before submitting a formal application to receive community input and feedback. Presentation at a PPM does not constitute City endorsement or approval of a project.

Townes Street Road Diet

The Townes Street Road Diet project consists of restriping Townes Street between Elford Street and West Park Avenue and will include the following improvements:

- Resurfacing
- A two-way, protected cycle track along the west side of the road
- Parallel parking spaces along the west side of the road
- Truck/Bus parking and parallel parking along the east side of the road

The project aligns with the recently completed Elford Street Road Diet and the pending safety improvements that SCDOT is proposing for River Street and Richardson St which is expected to be under construction in 2026/2027. The road diet will incorporate elements of traffic calming, create buffered pedestrian zones, expand parking in the CBD and create overflow truck/bus parking for the BSWA arena.

Contact:

Please contact Nick De Palma with the Engineering department with any questions you may have

Email: ndepalma@greenvillesc.gov

Phone: 864-467-4400

Townes Street Road Diet

Use the QR code below to see Engineering staff notes detailing all improvements at specific pinned locations. (in blue →)

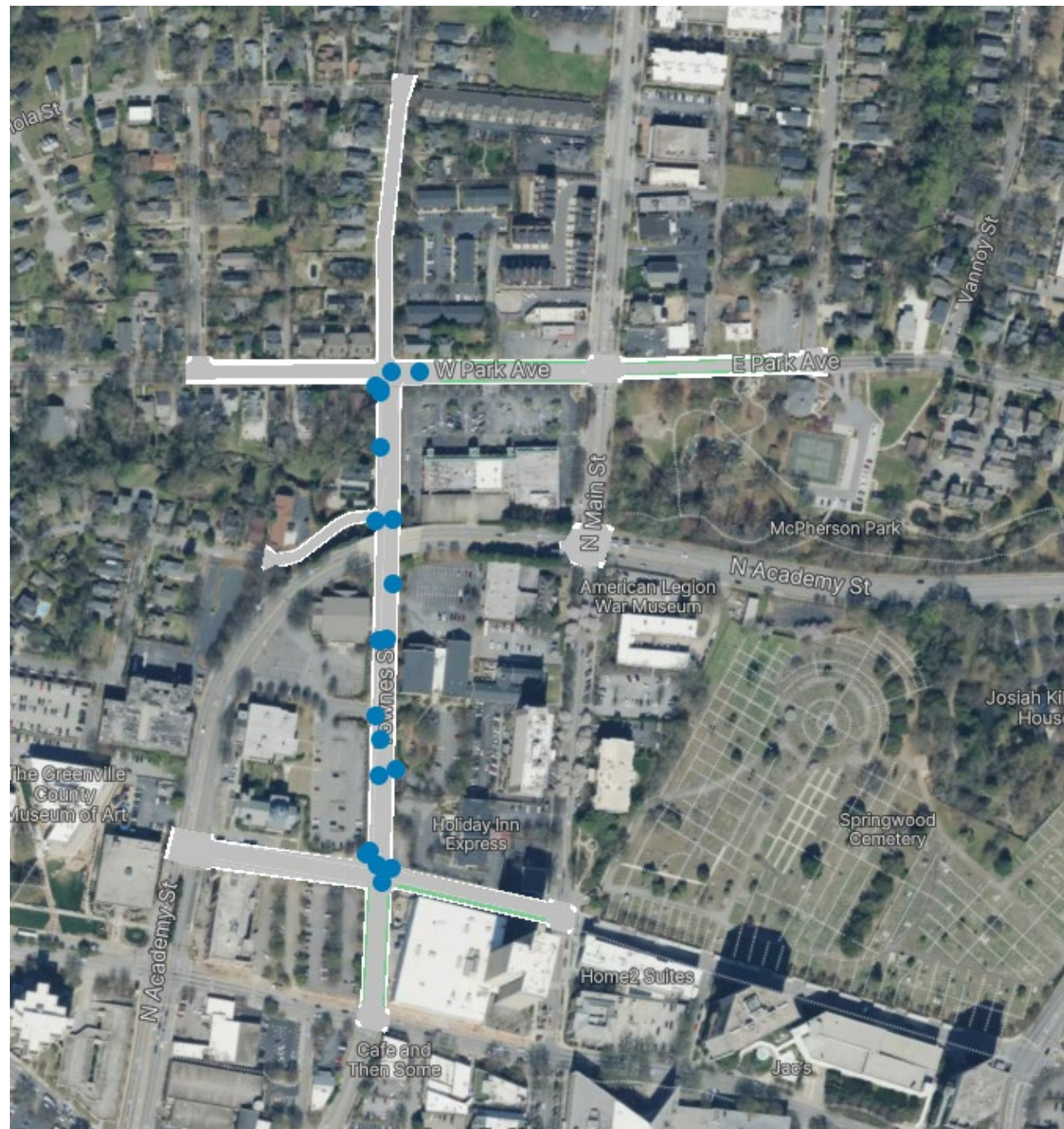
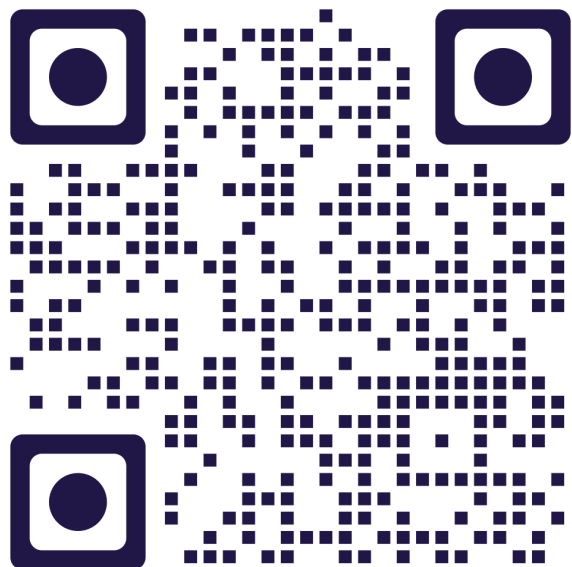

Certificate of Appropriateness: 701 Pendleton Street

Note: The City has not received a formal application for this item. The PPM is required before submitting a formal application to receive community input and feedback. Presentation at a PPM does not constitute City endorsement or approval of a project.

Certificate of Appropriateness: 701 Pendleton Street

- **Address:** 701 Pendleton Street
- **Parcel Numbers:** 0080000300100
- **Existing Zoning:** MX-2
- **Request:** Renovation and addition to a single-family residence
- **Next Step:** Design Review Board review

Contact:

Please contact Planning staff for applicant information

Email: planning@greenvillesc.gov

Phone: 864-467-4476

Certificate of Appropriateness: 701 Pendleton Street

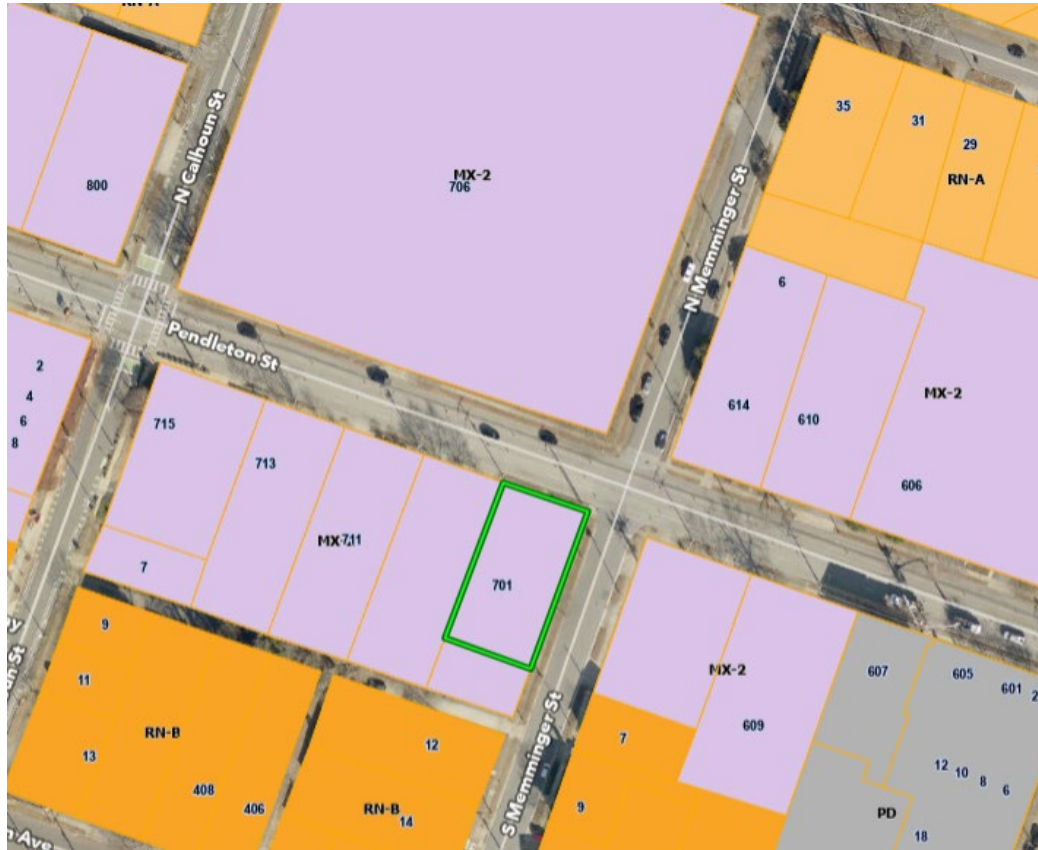

Certificate of Appropriateness: 701 Pendleton Street

Site Plan - Proposal

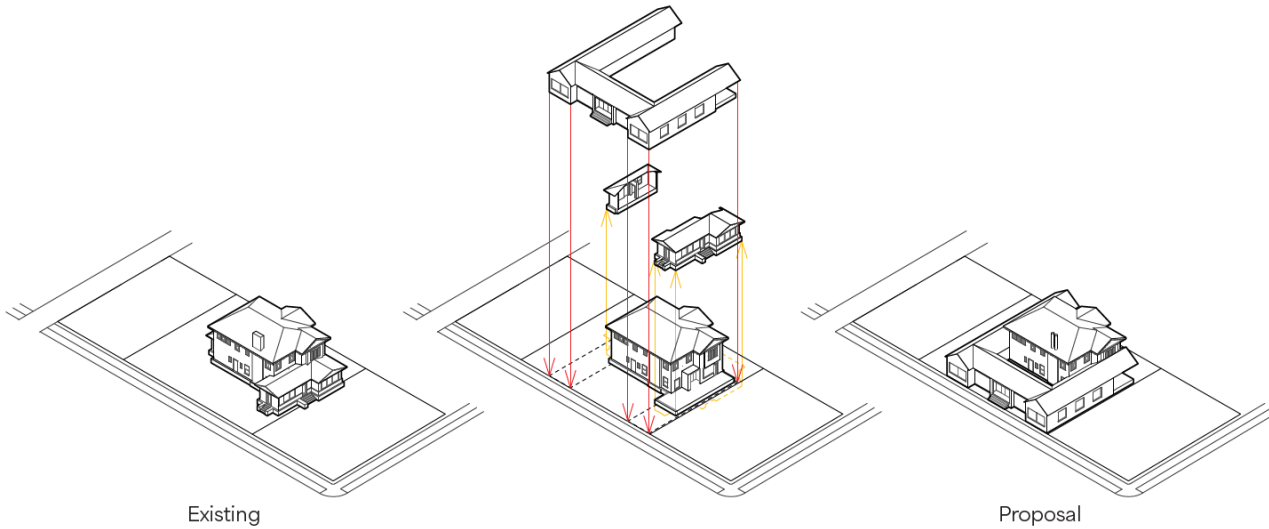
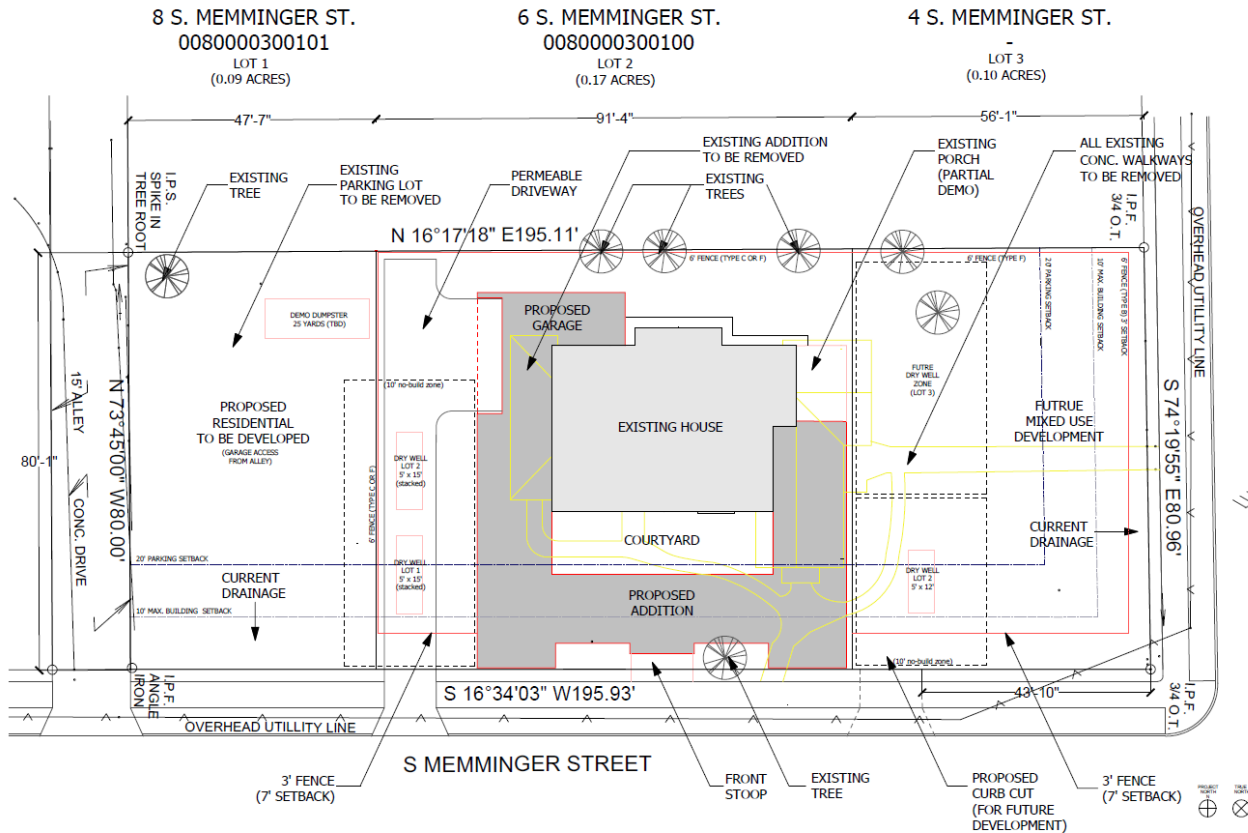

Existing

Proposal

Certificate of Appropriateness: 701 Pendleton Street

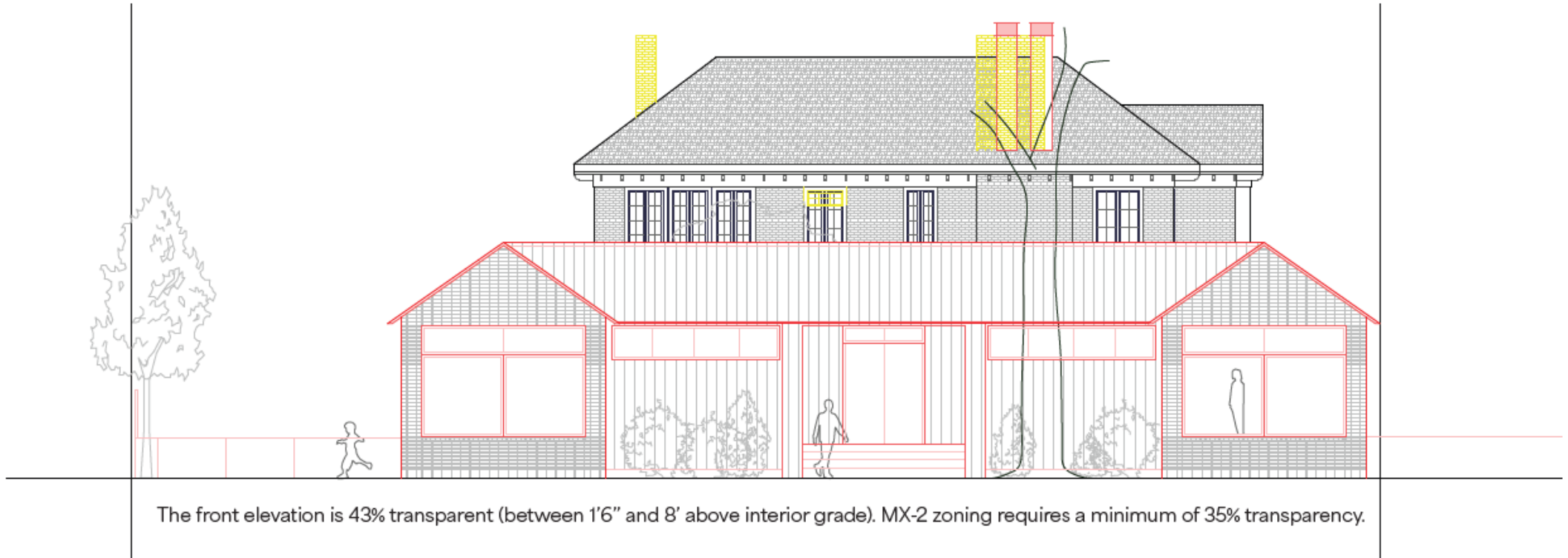

The front elevation is 43% transparent (between 1'6" and 8' above interior grade). MX-2 zoning requires a minimum of 35% transparency.

NEXT STEPS AND FREQUENTLY ASKED QUESTIONS

Next Steps

Depending on the type of project, it may proceed to permitting. Others require approval from a review board.

Project Type	Review Board?	Public Hearing Required?
Zoning map amendment (rezoning)	Planning Commission (Recommendation) City Council (Final Approval)	Yes
Major subdivision	Planning Commission	No
Street naming or re-naming	Planning Commission	Yes
Projects requiring a Major Certificate of Appropriateness (inside the Design Review Boundary or a Historic District)	Design Review Board or Historic Review Board	No
Residential project containing 12 or more units (outside Design Review Boundary)	No - project proceeds with permitting	N/A
Special exception permit	Board of Zoning Appeals	Yes

Frequently Asked Questions

Are members of the public allowed to attend the monthly Project Preview meeting?

Yes! Residents are encouraged to attend and learn about upcoming projects, ask questions, and share comments and concerns at the session.

Where can I learn more about the projects?

Please attend the Project Preview meeting to learn more about a specific project. Applications requiring approval from a review board will have additional information posted on the city website before the meeting or public hearing.

Will these projects require additional neighborhood meetings?

The Project Preview satisfies the procedural step for applications requiring a “Development Public Meeting” under the Greenville Development Code; an additional neighborhood meeting is not required. However, developers are encouraged to engage with neighborhoods at the beginning of their project and throughout the review process. Community members may contact the developer directly to share concerns or request additional opportunity for neighborhood input.

Frequently Asked Questions

How do I request changes to a development that I have concerns about?

Under the Greenville Development Code (effective July 15, 2023), some projects are permitted “by right,” meaning they can obtain a permit if they meet all requirements of the Code. The Development Code includes neighborhood protections such as building setbacks, height limits, landscaping and transition requirements, noise and light standards, and other requirements to reduce impacts on surrounding properties. If you believe a project does not comply with the required standards, please contact the Planning Office.

Other applications require a public hearing in front of a review board. The community may share concerns and ask the review board to require modifications at these public hearings. Certain applications such as rezonings require final approval by City Council.

What about other types of projects like hotels, restaurants, or new office buildings?

Currently, only applications requiring a “Development Public Meeting” under the Greenville Development Code must participate in the monthly Project Preview process. The city may invite developers to attend and share information about other major projects from time to time. In addition, the city may present updates on planning and engineering initiatives that are currently underway.

Questions

Please contact the Planning Office with any questions about the Project Preview meeting by calling 864-467-4476 or emailing planning@greenvillesc.gov.

Comments or concerns about proposed projects should be emailed to planning@greenvillesc.gov. This account is checked daily. Your message will be directed to the appropriate staff member for response.

To have the list of projects delivered to your inbox each month, sign up on the City's website at GreenvilleSC.gov/list.aspx

